

Universal Powerline Bus



UPB Wall Switch Dimmer (WS1D) Firmware Specification

V 1.5

03/18/04

Revision History

Rev	Date	Description
1.5	01-11-05	RLF – Fixed typo in section 10.2. Should be Direct Packet not Link Packet.
1.4	03-18-04	RLF – Initial release to public.
1.3	09-22-03	RLF – Updated Preliminary Release.
1.2	-	RLF – Updated Preliminary Release.
1.1	-	RLF – Initial Preliminary Release.

Table Of Contents

1. The Wall Switch 1 Dimmer (WS1D)	1
1.1. Light Dimmer	1
1.2. Rocker Switch	1
1.3. UPB Receiver.....	1
1.4. UPB Transmitter.....	2
1.5. UPB Core Logic	2
1.6. LED Indicator	2
1.7. Slave Switch.....	2
1.8. WS1D Connections.....	2
2. Modes Of Operation	3
2.1. Normal Mode.....	3
2.2. SETUP Mode	3
2.3. Factory Default Mode.....	3
3. UPB Setup Registers	4
3.1. The UPBID	5
3.2. The Configuration Registers.....	6
3.3. The Scratch-Pad Registers	7
4. Light Dimmer Operations	8
4.1. Light Levels	8
4.1.1. Pseudo-Logarithmic Dimming Curve	8
4.1.2. The Reset Light Level.....	8
4.1.3. The Last On Level	8
4.2. Fade Rates.....	8
4.3. Dimmer Options Register	9
4.3.1. The Dimming Capable Flag.....	10
4.3.2. The Default Fade Rate	10
5. Local Rocker Switch Operations	11
5.1. Rocker Switch Events	11
5.2. Rocker Switch Load Control.....	11
5.3. Configured Rocker Switch Dimmer Actions.....	12
5.3.1. The Rocker Switch Action Table	12
5.3.2. Default Rocker Switch Dimmer Actions	12
5.4. Rocker Switch Transmit Control.....	13
5.5. Rocker Switch Mode Control.....	13
5.5.1. Entering SETUP Mode	13
5.5.2. Exiting SETUP Mode.....	13
5.5.3. Entering Factory Default Mode.....	13
5.5.4. Exiting Factory Default Mode	14
5.6. Rocker Switch Power Disconnect	14

6. Slave Rocker Switch Operations	15
6.1. Slave Switch Connections.....	15
6.2. Slave Switch Events.....	15
6.3. Slave Switch Load Control	15
6.4. Slave Switch Transmit Control	15
6.5. Slave Switch Mode Control	16
7. Status LED Operation	17
7.1. The LED Options Register	17
7.2. LED Mode Selection	17
7.3. The Load Indicator LED Mode	17
7.4. The Diagnostic LED Mode	18
7.5. Special Mode LED Indications	18
7.6. Firmware Version LED Indication.....	18
8. UPB Message Receiving	19
8.1. Receive Components.....	19
8.1.1. Receiving UPB Link Packets	20
8.1.2. Activating/Deactivating Receive Components	20
8.1.3. Changing Preset Light Levels and Fade Rates	20
8.2. Receiving The Core Command Message Set	20
8.3. Receiving The Device Control Command Set.....	20
8.4. The “Activate” Command	21
8.5. The “Deactivate” Command	21
8.6. The “Goto” Command	21
8.7. The “Fade Start” Command	22
8.8. The “Fade Stop” Command.....	22
8.9. The “Blink” Command	22
8.10. The “Store Preset” Command	22
8.11. The “Report Status” Command	22
9. Rocker Switch Triggered Transmissions	23
9.1. Transmit Components.....	23
9.1.1. The Transmit Link ID	24
9.1.2. The Transmit Command ID	24
9.2. Using Command IDs	24
9.3. The UPB Transmit Command Table	24
9.3.1. Send State Report.....	25
9.4. The UPB Transmit Control Register	25
9.4.1. Link Packet Enable.....	26
9.4.2. Acknowledge Message Request	26
9.4.3. ID Pulse Request.....	27
9.4.4. ACK Pulse Request.....	27
9.4.5. Transmission Count.....	27
10. Automatic State Report Transmissions	28
10.1. Enabling Automatic State Reports	28

10.2. Transmitting Automatic State Reports.....28

11. Factory Default Operation29

11.1. Power-Up Operation29

11.2. Dimmer Operation.....29

11.3. Local Rocker Switch Events.....29

11.4. Slave Rocker Switch Events30

11.5. UPB Communication Packet Receptions30

11.6. UPB Receive Components.....30

11.7. Activate Link Command Operation.....31

11.8. Deactivate Link Command Operation31

11.9. Changing Preset Light Levels31

11.10. UPB Communication Packet Transmissions31

1. The Wall Switch 1 Dimmer (WS1D)

The Wall Switch 1 Dimmer (WS1D) is a wall mounted dimming light switch capable of controlling the light level of a single 600W (or 1000W, or 2000W) channel 120VAC lighting load. The WS1D has three separate ways that can be employed to control its light level: 1) Local Rocker Switch, 2) Remote Slave Switches, and 3) Universal Powerline Bus™ (UPB) Commands. In addition to controlling the lighting load, the WS1D can be configured to transmit a set of UPB Commands or Reports onto the powerline when certain Rocker Switch (or Slave Switch) events occur. The WS1D also contains a single bi-color LED to indicate status, modes, and events.

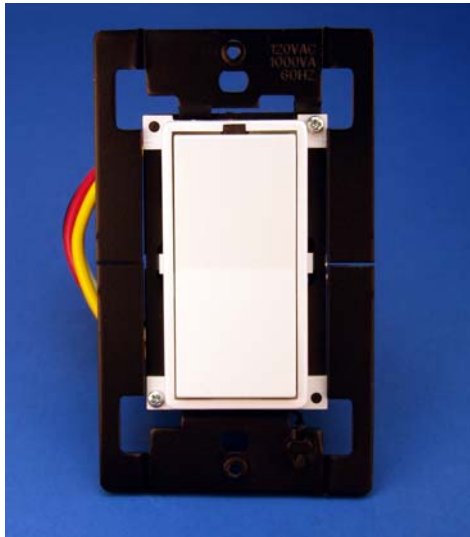

Figure 1: The UPB Wall Switch 1 Dimmer (WS1D)

1.1. Light Dimmer

The WS1D has Light Dimmer logic capable of producing 200 different levels of light output as well as off. The Light Dimmer can be configured (or commanded) to change light levels immediately (“Snap”) as well as gradually (“Fade”).

1.2. Rocker Switch

The WS1D has a decora-style Rocker Switch made up of two momentary pushbutton switches: one at the top and one at the bottom. The Rocker Switch can be used to set new light levels, set new operating modes, and to trigger transmission of UPB messages.

1.3. UPB Receiver

The WS1D has UPB Receiver Logic capable of receiving UPB Communication Packets from the powerline.

1.4. UPB Transmitter

The WS1D has UPB Transmitter Logic capable of transmitting UPB Communication Packets onto the powerline.

1.5. UPB Core Logic

The WS1D conforms to the UPB System Model as defined in the UPB System Description document. The WS1D has UPB Core Logic capable of responding to the UPB Core Command Message Set as described in the UPB System Description document.

1.6. LED Indicator

The WS1D has a bi-color LED indicator used to indicate its current status and mode of operation.

1.7. Slave Switch

The WS1D has a special input (wire) for connecting an optional Slave Switch (part # PCS SSR3), which can be used to control the WS1D in a similar fashion to the WS1D's local Rocker Switch

1.8. WS1D Connections

The WS1D **shall** have four wires that are used to connect it to power, load, and an optional slave switch. Figure 2 shows how the WS1D connects to the lighting system.

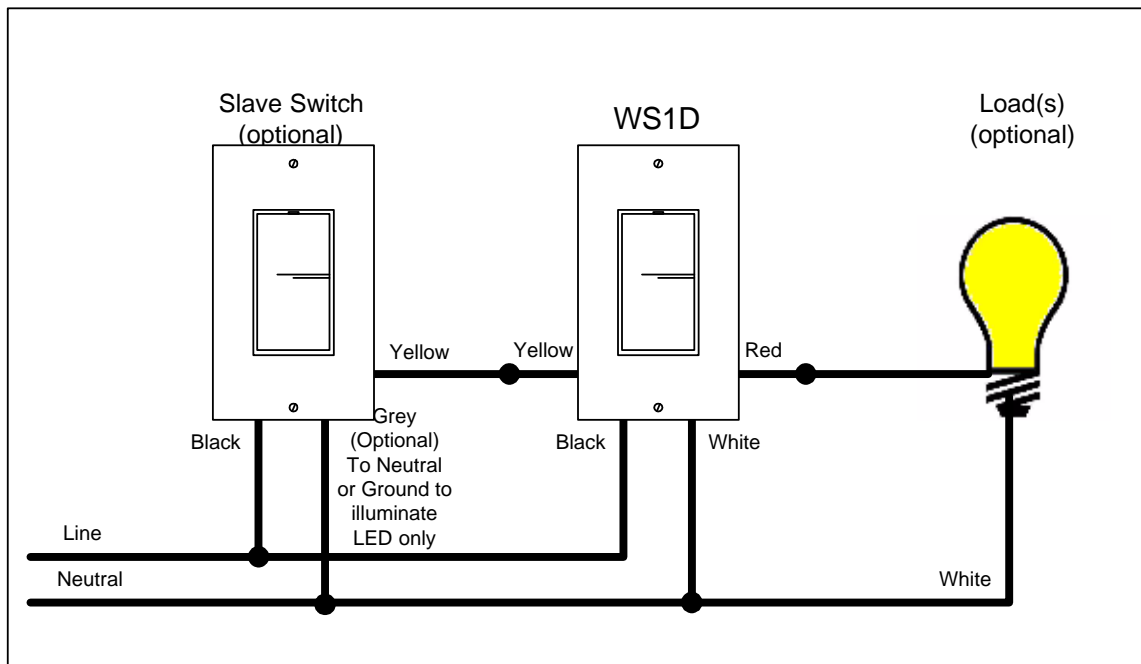

Figure 2: WS1D Connections To A Lighting System

2. Modes Of Operation

The WS1D **shall** be capable of being put into any of three different modes of operation: Normal Mode, SETUP Mode, and Factory Default Mode.

2.1. Normal Mode

The WS1D **shall** be able to operate in the Normal Mode. The Normal Mode is the WS1D's default mode of operation. While in the Normal Mode the WS1D **shall** be able to perform all of its normal operations except that Setup Register Write Protection is enabled. While in the Normal Mode, the LED indicator **shall** indicate this mode of operation as defined in section 7.5 "Special Mode LED Indications".

2.2. SETUP Mode

The WS1D **shall** be able to operate in the SETUP Mode. The SETUP Mode is a special mode of operation that every UPB device that conforms to the UPB System Model must have. The UPB System Description document describes the SETUP Mode in more detail. The WS1D **shall** be able to enter into the SETUP Mode by two different methods. One is by receiving a valid "Start SETUP Mode" command message over the powerline as described in the UPB System Description document. The other method is by having its Rocker Switch (or Slave Switch) physically touched in a special sequence as described in section 5.5.1 - "Entering SETUP Mode". While in the SETUP Mode, the LED indicator **shall** indicate this mode of operation as defined in section 7.5 "Special Mode LED Indications".

2.3. Factory Default Mode

The WS1D **shall** be able to operate in the Factory Default Mode. The Factory Default Mode is a special mode of operation that, when entered, sets the Setup Registers to their Factory Default values as defined in Table 1 and Table 2. The WS1D **shall** be able to enter into the Factory Default Mode as described in section 5.5.3 - "Entering Factory Default Mode". While in the Factory Default Mode, the LED indicator **shall** indicate this mode of operation as defined in section 7.5 "Special Mode LED Indications".

3. UPB Setup Registers

Like all UPB devices that conform to the UPB System Model, the WS1D **shall** have a set of non-volatile 8-bit registers known as UPB Setup Registers. The WS1D **shall** have a total of 256 UPB Setup Registers. These registers are used to define and configure how the WS1D will operate as well as to store other important information as described herein. The WS1D **shall** allow read/write access to its UPB Setup Registers via special UPB Messages communicated on the powerline. The WS1D's Setup Registers are partitioned into three main groups (the UPBID, the Configuration Registers, and the Scratch-Pad Registers) as described below.

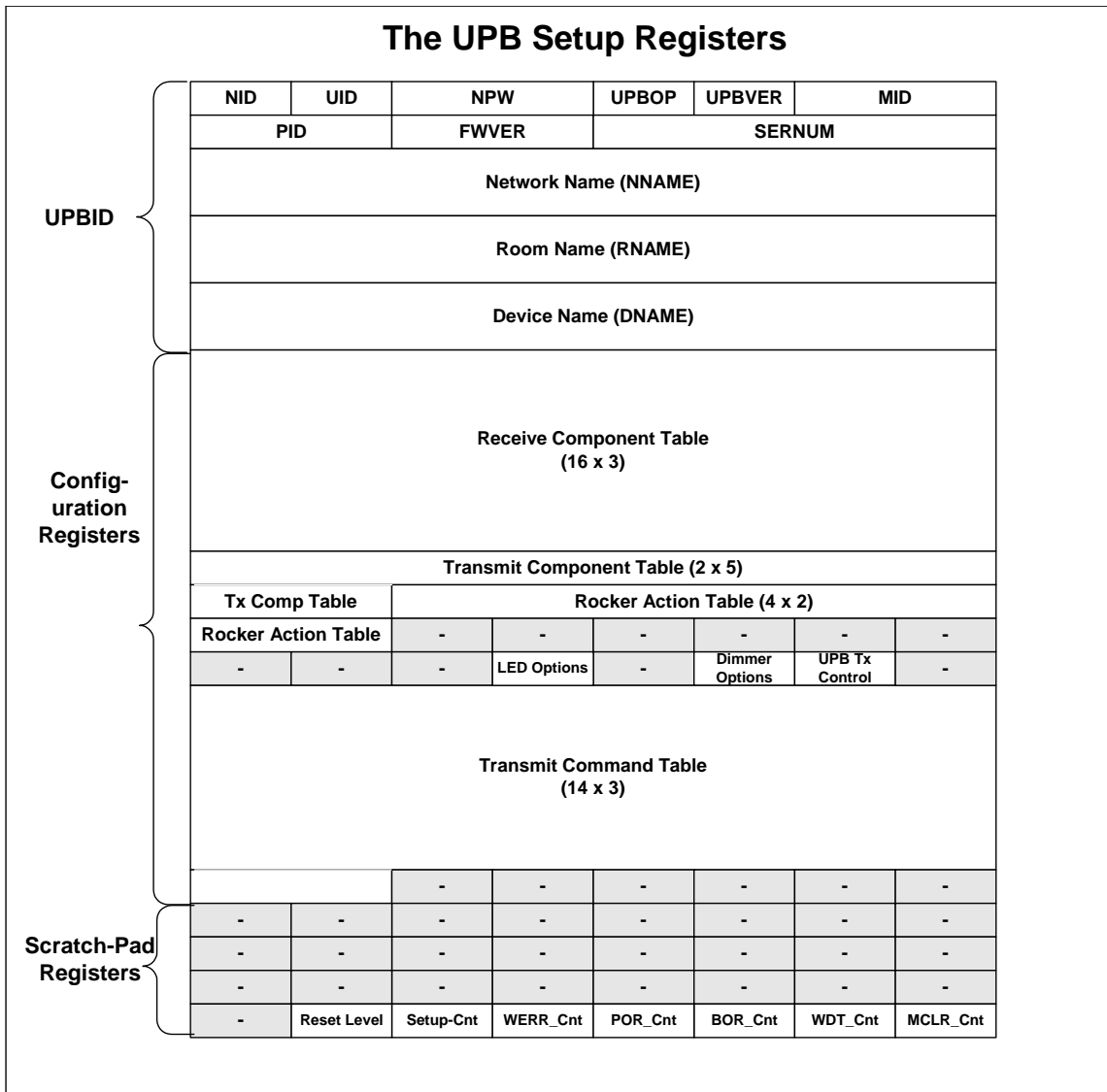

Figure 3: The WS1D UPB Setup Registers

3.1. The UPBID

The UPBID is a set of 64 non-volatile registers that contains information that uniquely identifies the individual UPB device. The WS1D **shall** implement the UPBID in the first 64 Setup Registers. Table 1 below describes the Setup Registers that make up the UPBID. The table describes each register's use as well as its factory default value. The UPB System Description document contains more detailed information about the UPBID.

Setup Register Field Name	Reg. Num.	Factory Default	Description
Network ID (NID)	0x00	255 (0xFF)	Unique identifier (1 – 255) for the UPB Network that this device communicates on.
Unit ID (UID)	0x01	01 (0x01)	Unique identifier (1 – 255) for this UPB device.
Network Password (NPW)	0x02 – 0x03	4660 (0x1234)	Password designed to keep unauthorized users from modifying the Setup Registers of this device.
UPB Options (UPBOP)	0x04	00 (0x00)	Identifies UPB Options that are enabled for this device.
UPB Version (UPBVER)	0x05	01 (0x01)	Identifies the version of the UPB specification this device conforms to.
Manufacturer ID (MID)	0x06 – 0x07	01 (0x0001) PCS	Unique identifier of the manufacturer of this UPB device.
Product ID (PID)	0x08 – 0x09	01 (0x0001) WS1D	The manufacturer's unique product identifier for this UPB device.
Firmware Version (FWVER)	0x0A – 0x0B	Depends on the current F/W	Identifies the version of firmware in this device.
Serial Number (SERNUM)	0x0C – 0x0F	Set by the manufacturer	The manufacturer's unique serial number for this UPB device.
Network Name (NNAME)	0x10 – 0x1F	"New Network Name"	A human readable (ASCII) name for the UPB Network that this device communicates on.

Setup Register Field Name	Reg. Num.	Factory Default	Description
Room Name (RNAME)	0x20 – 0x2F	“New Room Name ”	A human readable (ASCII) name for the Room that this UPB device is installed in.
Device Name (DNAME)	0x30 – 0x3F	“New PCS WS1(D) ”	A human readable (ASCII) name for this UPB device.

Table 1: The Wall Switch Dimmer’s UPBID

3.2. The Configuration Registers

The Configuration Registers are a set of non-volatile registers that configure how a device will operate. The WS1D **shall** implement the Configuration Registers in the next 128 Setup Registers. The definition of the Configuration Registers is application dependent. Table 2 describes the Configuration Registers for the WS1D application. The table describes each register’s use as well as its factory default value.

Setup Register Field Name	Reg. Num.	Factory Default	Description
Receive Component Table	0x40 – 0x6F	See Table 10 for factory defaults	Configuration table containing 16 Receive Component Records used for receiving UPB Link Packets.
Transmit Component Table	0x70 – 0x79	See Table 12 for factory defaults	Configuration table containing 2 Transmit Component Records used for transmitting UPB Link Packets.
Rocker Action Table	0x7A – 0x81	See Table 7 for factory defaults	Configuration table that defines the Dimmer actions to be performed upon single-tap and double-tap events on the Top and Bottom Rocker switches.
Unused	0x82 – 0x8A	255 (0xFF)	Unused
LED Options	0x8B	138 (0x8A)	Configurable options for the Status LED.
Unused	0x8C	255 (0xFF)	Unused
Dimmer Options	0x8D	131 (0x83)	Configurable options for the light dimmer circuit.

Setup Register Field Name	Reg. Num.	Factory Default	Description
UPB Tx Control	0x8E	132 (0x84)	Configurable options for UPB Transmissions.
Unused	0x8F	255 (0xFF)	Unused
Transmit Command Table	0x90 – 0xBC	See Table 13 for factory defaults	Table for 16 Command IDs (CmdIds) with the 3-byte UPB Command Messages they represent.
Unused	0xBD – 0xBF	255 (0xFF)	Unused

Table 2: The Wall Switch Dimmer’s Configuration Registers

3.3. The Scratch-Pad Registers

The Scratch-Pad Registers are a set of non-volatile registers that the application can use for any purpose. The WS1D **shall** implement the Scratch-Pad Registers in the last 64 Setup Registers. Table 3 describes the Scratch-Pad Registers for the Wall Switch Dimmer. The table describes each register’s location and use. Note: there are no factory default values for these registers.

Setup Register Field Name	Reg. Num.	Description
Unused	0xC0 – 0xF8	Unused
Reset Light Level	0xF9	Location to store the last Light Level before power-down.
Setup Mode Counter	0xFA	Count of number of times this device went into Setup Mode.
WERR Counter	0xFB	Count of number of times this device had a EEPROM Write Error.
POR Counter	0xFC	Count of number of times this device had a Power-On Reset.
BOR Counter	0xFD	Count of number of times this device had a Brown-Out Reset.
WDT Counter	0xFE	Count of number of times this device had a Watchdog Timer Reset.
MCLR Counter	0xFF	Count of number of times this device had a Master Clear Reset.

Table 3: The Wall Switch Dimmer’s Scratch-Pad Registers

4. Light Dimmer Operations

4.1. Light Levels

The WS1D dimmer output **shall** be capable of creating any of 200 distinct Light Levels (1 – 200) as well as OFF (0). Light Level #0 corresponds to 0% (OFF) and Light Level #200 corresponds to 100% (MAX). When the WS1D sets its Light Level to a new value, it can either do it immediately, called a “Snap”, or it can do it gradually over time, called a “Fade”. The WS1D can be configured (or commanded) to use one of sixteen possible Fade Rates in setting its new Light Level (see Section 4.1.3).

4.1.1. Pseudo-Logarithmic Dimming Curve

The WS1D **shall** implement a pseudo-logarithmic dimming curve for creating smooth lighting transitions between its 200 Light Levels.

4.1.2. The Reset Light Level

Approximately once every 2 seconds the WS1D **shall** save its current Light Level (in %) into non-volatile memory as the Reset Light Level. When the WS1D first powers up, it **shall** restore its current Light Level (%) to the saved Reset Light Level value.

4.1.3. The Last On Level

Approximately once every 2 seconds the WS1D **shall** save its current non-zero Light Level (in %) into non-volatile memory as the Last On Level. Whenever the WS1D is configured (or commanded) to go to a Light Level above 100% it **shall** use the Last On Level instead.

4.2. Fade Rates

Whenever the WS1D sets its Light Level to a new value, it can either do it immediately, called a Snap, or it can do it a little bit at a time, called a Fade. The WS1D **shall** be able to be configured or commanded to use one of sixteen possible Fade Rates (including Snap) in setting its new Light Level as described in Table 4 below.

Fade Rate	Fade Time (0% – 100%)	Time Per Step
0	Snap!	0
1	0.8 seconds	4.167mS
2	1.6 seconds	8.333 mS
3	3.3 seconds	16.67mS
4	5 seconds	25mS
5	6.6 seconds	33.3 mS
6	10 seconds	50 mS
7	20 seconds	100 mS
8	30 seconds	150 mS
9	1 minute	300 mS
10	2 minutes	600 mS
11	5 minutes	1.5 seconds
12	10 minutes	3 seconds
13	15 minutes	4.5 seconds
14	0.5 hours	9 seconds
15	1.0 hour	18 seconds

Table 4: WS1D Dimmer Fade Rates

4.3. Dimmer Options Register

The WS1D **shall** have an 8-bit Dimmer Options Register implemented at address 0x8D of its non-volatile Setup Registers. The Dimmer Options Register (Figure 4) has bits and fields that are used to customize the dimmer operation using a UPB Setup Tool.

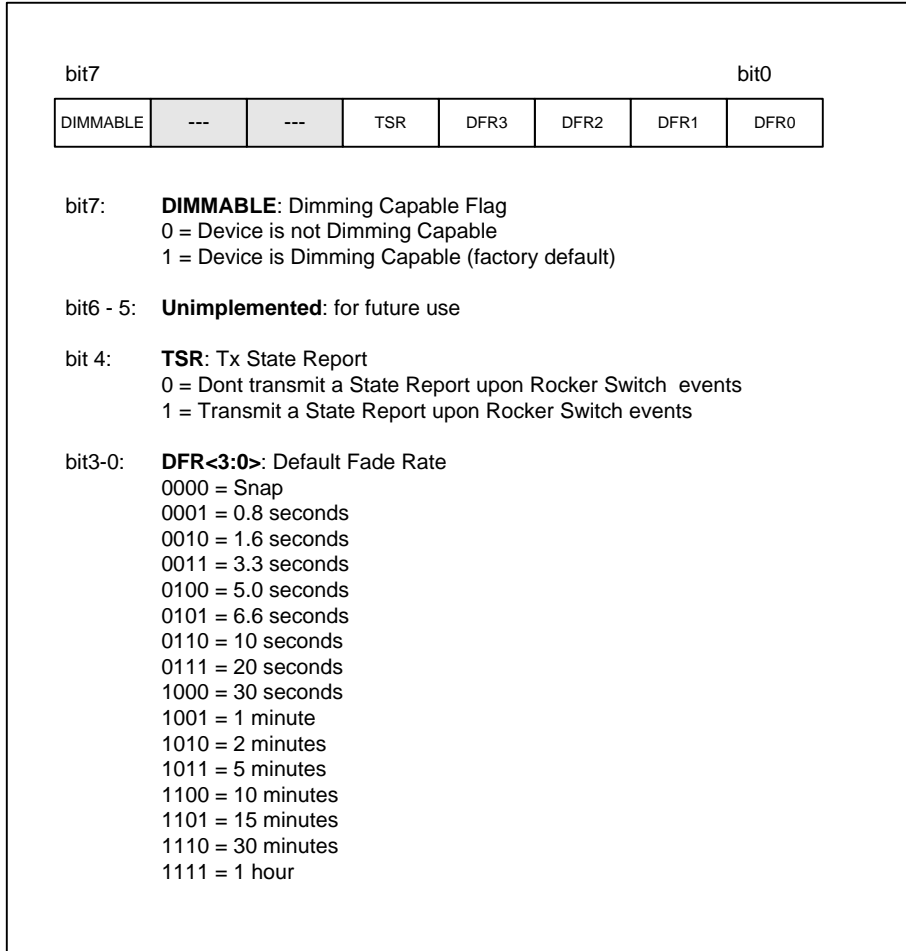

Figure 4: The Dimmer Options Register

4.3.1. The Dimming Capable Flag

The WS1D **shall** have a 1-bit Dimming Capable Flag implemented as part of its Dimmer Options Setup Register (Figure 4). When this flag is set to 1 (factory default state), the WS1D **shall** allow full 200 level light dimming capabilities. When this flag is cleared to 0, the WS1D **shall** only allow On (100%) and Off (0%) capabilities.

4.3.2. The Default Fade Rate

The WS1D **shall** have a 4-bit Default Fade Rate implemented as part of its Dimmer Options Register (Figure 4). Whenever the WS1D is commanded to use the “default fade rate” it **shall** use the value in the Default Fade Rate field of the Dimmer Options Register. Also, whenever the WS1D is commanded or configured to use a Fade Rate value above 15 it **shall** use the value in the Default Fade Rate field instead.

5. Local Rocker Switch Operations

The WS1D has a decora-style Rocker Switch that is used to control the lighting load, transmit UPB Messages, and to put the WS1D into special modes of operation. The Rocker Switch consists of two momentary pushbutton switches: one at the top of the Rocker and one at the bottom of the Rocker.

5.1. Rocker Switch Events

The WS1D **shall** be capable of detecting any of the four types of Rocker Switch Events defined in Table 5 below on both of its Rocker Switches.

Rocker Event	Definition
Single-Tap	The switch is pressed for at least 250 mS and then released before 750 mS and left released.
Multi-Tap (Double-Tap)	The switch is pressed for at least 250 mS and then released and pressed again before 750 mS and then released before 750 mS and left released.
Hold	The switch is pressed for at least 750 mS without being released.
Release	The switch was released after a Hold event.

Table 5: Rocker Switch Events

5.2. Rocker Switch Load Control

The Rocker Switch **shall** be used by the WS1D to control its dimmer's Light Level output as defined in Table 6 below.

Rocker Event	Dimmer Action (Top Rocker)	Dimmer Action (Bottom Rocker)
Single-Tap	Perform the Configured Rocker Switch Dimmer Action as described in section 5.3.	Perform the configured Rocker Switch Dimmer Action as described in section 5.3.
Double-Tap	Perform the Configured Rocker Switch Dimmer Action as described in section 5.3.	Perform the configured Rocker Switch Dimmer Action as described in section 5.3.
Hold	Start fading to 100% at the Default Fade Rate.	Start fading to 0% at the Default Fade Rate.
Release	Stop fading the Light Level.	Stop fading the Light Level.

Table 6: Rocker Switch Load Control

5.3. Configured Rocker Switch Dimmer Actions

The WS1D treats the Single-Tap and Double-Tap Rocker Switch Events specially, giving the user the freedom to configure the corresponding light dimmer action that they desire. The WS1D **shall** implement a Rocker Switch Action Table in its non-volatile Setup Registers as shown in Table 7 to configure the “Dimmer Action” to be performed on the load upon a Single-Tap and upon a Double-Tap event of the two Rocker Switches.

5.3.1. The Rocker Switch Action Table

The Rocker Switch Action Table **shall** be used to configure the “Dimmer Action” to be performed on the load upon a Single-Tap and/or Double-Tap event. Each “Dimmer Action” **shall** be defined as a Light Level (%) to fade to and an associated Fade Rate to use to get it there. The Rocker Switch Action Table (Table 7) **shall** be 8 bytes long and **shall** be divided into four 2-byte records. There **shall** be one record to correspond to each of the following events: Top Rocker Single-Tap, Top Rocker Double-Tap, Bottom Rocker Single-Tap, and Bottom Rocker Double-Tap. Each 2-byte record consists of one byte to represent the Light Level (%) and the other byte to represent the Fade Rate to use when the corresponding event occurs.

Setup Register Field Name	Reg. Num.	Factory Default		Description
		Level	Rate	
Top Rocker Single-Tap Dimmer Action	0x7A – 0x7B	100	255	Light Level (%) and Fade Rate to go to upon a single-tap event on the Top Rocker switch.
Top Rocker Double-Tap Dimmer Action	0x7C – 0x7D	100	000	Light Level (%) and Fade Rate to go to upon a double-tap event on the Top Rocker switch.
Bottom Rocker Single-Tap Dimmer Action	0x7E – 0x7F	000	255	Light Level (%) and Fade Rate to go to upon a single-tap event on the Bottom Rocker switch.
Bottom Rocker Double-Tap Dimmer Action	0x80 – 0x81	000	000	Light Level (%) and Fade Rate to go to upon a double-tap event on the Bottom Rocker switch.

Table 7: The Rocker Switch Action Table

5.3.2. Default Rocker Switch Dimmer Actions

As an example of using the Rocker Switch Action Table let’s explore how the WS1D will behave when set to its factory default values. The factory defaults for the Rocker Switch Action Table are shown in Table 7. With these values set the WS1D should behave as described in Table 8 below.

Rocker Event	Dimmer Action (Top Rocker)	Dimmer Action (Bottom Rocker)
Single-Tap	Fade to 100% at the Default Fade Rate.	Fade to 0% at the Default Fade Rate.
Double-Tap	Snap to 100% at Fade Rate #0.	Snap to 0% at Fade Rate #0.
Hold	Start fading to 100% at the Default Fade Rate.	Start fading to 0% at the Default Fade Rate.
Release	Stop fading the Light Level.	Stop fading the Light Level.

Table 8: Factory Default Rocker Switch Dimmer Actions

5.4. Rocker Switch Transmit Control

The WS1D can optionally be configured to transmit UPB Messages when any of the Rocker Switch Events listed in Table 5 occurs. Refer to section 8 for details on how to configure the WS1D for Rocker Switch Transmissions.

5.5. Rocker Switch Mode Control

The Rocker Switch **shall** be able to be used to put the WS1D into different modes of operation. The WS1D has three different modes of operation (Normal Mode, SETUP Mode, and Factory Default Mode) as defined in section 2.

5.5.1. Entering SETUP Mode

The WS1D **shall** enter SETUP Mode when either Rocker Switch is multi-tapped for exactly 5 times. When the WS1D enters the SETUP Mode it **shall** indicate so by flashing its dimmer’s lighting load on and off and by blinking its LED as defined in section 7.5.

5.5.2. Exiting SETUP Mode

Once in the SETUP Mode, the WS1D **shall** exit SETUP Mode and enter the Normal Mode when either Rocker Switch is multi-tapped for exactly 2 times. When the WS1D exits the SETUP Mode it will indicate so by flashing its dimmer’s lighting load on and off and by stopping the blinking of its LED as defined in section 7.5.

5.5.3. Entering Factory Default Mode

Once in the SETUP Mode, the WS1D **shall** exit SETUP Mode and enter the Factory Default Mode when either Rocker Switch is multi-tapped for exactly 10 times. When the WS1D enters the Factory Default Mode it will indicate so by flashing its dimmer’s lighting load on and off and by blinking its LED as defined in section 7.5.

5.5.4. Exiting Factory Default Mode

Once in the Factory Default Mode, the WS1D **shall** exit Factory Defaults Mode and enter the Normal Mode when either Rocker Switch is multi-tapped for exactly 2 times. When the WS1D exits the SETUP Mode it will indicate so by flashing its dimmer's lighting load on and off and by stopping the blinking of its LED as defined in section 7.5.

5.6. Rocker Switch Power Disconnect

As a special safety feature, the power to the WS1D can be disconnected by pressing the bottom rocker with extra force until a relatively loud "snap" sound is heard. The rocker switch will stay in this pressed position, which disconnects power from the WS1D internal circuitry. To re-apply the power, simply press the Top Rocker until the rocker snaps out of this position and back into its normal operational position.

6. Slave Rocker Switch Operations

The WS1D **shall** be capable of being connected to an optional Slave Switch (part # PCS SSR3), which can be used to control the WS1D in a similar fashion to the WS1D's own local Rocker Switch.

6.1. Slave Switch Connections

Figure 5 shows how the Slave Switch is connected to the WS1D.

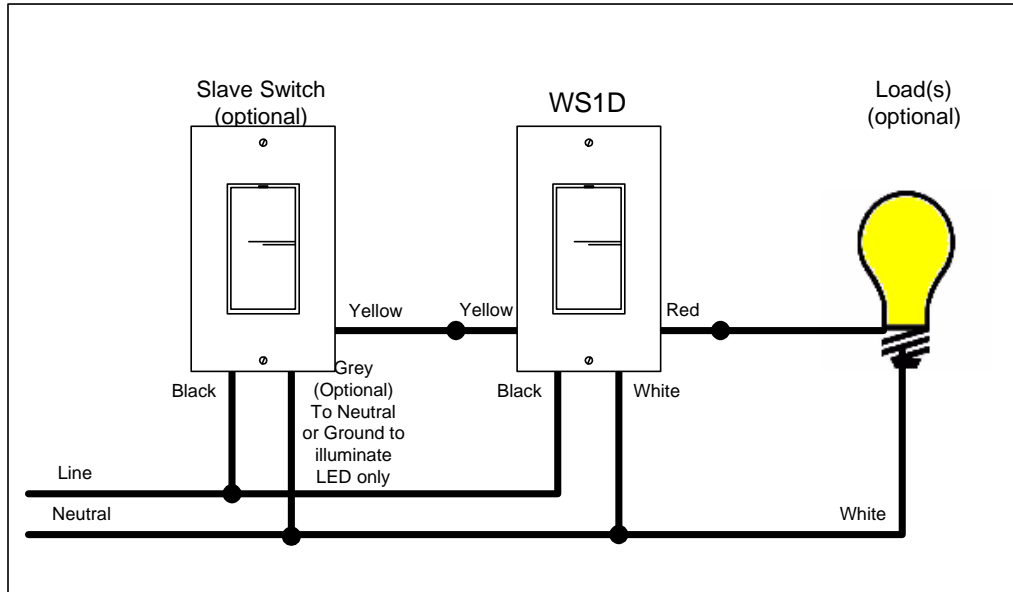

Figure 5: Connecting A Slave Switch

6.2. Slave Switch Events

The WS1D **shall** be able to detect the same four types of Rocker Switch Events defined in Table 5 on its connected Slave Switch.

6.3. Slave Switch Load Control

The WS1D **shall** perform the same Load Control operations based on its Slave Switch as it is specified to do based on its Rocker Switch per section 5.2

6.4. Slave Switch Transmit Control

The WS1D **shall** perform the same Transmit Control operations based on its Slave Switch as is specified to do based on its Local Rocker Switch per section 5.3.2.

6.5. Slave Switch Mode Control

The WS1D **shall** perform the same Mode Control operations based on its Slave Switch as it is specified to do based on its Rocker Switch per section 5.5.

7. Status LED Operation

The WS1D has a single bi-color Light Emitting Diode (LED) that it uses to indicate its current status. The Status LED is configured by the settings in the LED Options Register (as defined below).

7.1. The LED Options Register

The WS1D shall have an 8-bit LED Options Register implemented at address 0x8B of its non-volatile Setup Registers. The LED Options Register (Table 9) has bits and fields that are used to customize the Status LED operation using a UPB Setup Tool.

Bit	Name	Description
7	LED Mode	0 = Load Indicator LED enabled 1 = Diagnostic LED enabled
6 - 4	Unused	Unused
3 - 2	Load On Color	00 = Black (off) 01 = Red 10 = Green 11 = Orange
1 - 0	Load Off Color	00 = Black (off) 01 = Red 10 = Green 11 = Orange

Table 9: The LED Options Register

7.2. LED Mode Selection

Bit #7 of the LED Options Register is used to select between two different LED Modes: The Load Indicator LED Mode or the Diagnostic LED Mode. If bit #7 is clear (0) then the WS1D **shall** operate the Status LED in the Load Indicator LED Mode as described in Section 7.3. If bit #7 is set (1) then the WS1D **shall** operate the Status LED in the Diagnostic LED Mode as described in Section 7.4.

7.3. The Load Indicator LED Mode

If the Load Indicator LED Mode is enabled, the WS1D shall turn the Status LED to a color based on the on/off state of the dimmer output. If the dimmer output is set to 0% (off) the WS1D **shall** set the Status LED to the color specified by the Load Off Color bits (1 and 0) of the LED Options Register as defined in Table 9. If the dimmer output is set above 0% the WS1D **shall** set the Status LED to the color specified by the Load On Color bits (3 and 2) of the LED Options Register as defined in Table 9.

7.4. The Diagnostic LED Mode

If the Diagnostic LED Mode is enabled, the WS1D **shall** turn the Status LED solid orange. Whenever the WS1D transmits a UPB message, it **shall** indicate so by blinking the status LED red. Whenever the WS1D receives a valid UPB message, it **shall** indicate so by blinking the status LED green. Whenever the WS1D receives an invalid UPB message, it **shall** indicate so by blinking the status LED black (off).

7.5. Special Mode LED Indications

The WS1D has two special modes that it can be put into: SETUP Mode and Factory Default Mode. When the WS1D is in SETUP Mode it **shall** indicate so by blinking its status LED alternately between green and black (off). When the WS1D is in Factory Default Mode it **shall** indicate so by blinking its status LED alternately between red and black (off). When the WS1D is in Normal Mode it **shall** indicate so by stopping the blinking and turning its status LED to solid orange.

7.6. Firmware Version LED Indication

When power is first applied, the WS1D **shall** use the status LED to indicate the version of the firmware it is running. It **shall** do this by blinking the LED four times. Each blink will either be red or green. The four blinks **shall** be such as to indicate the binary value that matches the least significant digit of the firmware version. A blink of red **shall** indicate a binary “zero” and a blink of green **shall** indicate a binary “one”. As an example, if the firmware version is 4.15, then the LED will indicate the binary value for 5, which is 0-1-0-1. The WS1D will therefore blink its LED four times upon power-up: red-green-red-green.

8. UPB Message Receiving

The WS1D **shall** be capable of receiving UPB messages from the powerline.

8.1. Receive Components

The WS1D uses the concept of Receive Components (as described in the UPB System Description document) to configure its UPB Link Packet receiving behavior. The WS1D **shall** have sixteen 3-byte Receive Components implemented in its non-volatile Configuration Registers as shown in Table 10. All sixteen Receive Components (referred to as Presets) are associated with the dimmer’s single light dimmer output. Each Receive Component **shall** have an associated Link ID byte that is used when receiving UPB Link Packets. Each Receive Component **shall** also have an associated byte for holding a Light Level and Fade Rate for use in processing the “Activate” and “Deactivate” commands (see section 8 for details).

Setup Register Field Name	Register Numbers	Factory Default Values		
		Link ID	Light Level	Fade Rate
Preset #1	0x40 – 0x42	001	100	255
Preset #2	0x43 – 0x45	002	0	255
Preset #3	0x46 – 0x48	003	80	255
Preset #4	0x49 – 0x4B	004	60	255
Preset #5	0x4C – 0x4E	005	40	255
Preset #6	0x4F – 0x51	006	20	255
Preset #7	0x52 – 0x54	007	100	255
Preset #8	0x55 – 0x57	008	0	255
Preset #9	0x58 – 0x5A	009	80	255
Preset #10	0x5B – 0x5D	010	60	255
Preset #11	0x5E – 0x60	011	40	255
Preset #12	0x61 – 0x63	012	20	255
Preset #13	0x64 – 0x66	013	100	255
Preset #14	0x67 – 0x69	014	100	255
Preset #15	0x6A – 0x6C	015	100	255
Preset #16	0x6D – 0x6F	016	100	255

Table 10: Receive Component Table

8.1.1.Receiving UPB Link Packets

Whenever the WS1D receives a UPB Link Packet it will attempt to match its Destination ID to one of the valid Link IDs of its sixteen Receive Components. If a match is not found then that Link Packet is not for this WS1D and it **shall** be ignored. If a match is found then the WS1D **shall** accept the Link Packet for further processing. The particular Receive Component that had the Link ID match is “linked” to this Link Packet.

8.1.2.Activating/Deactivating Receive Components

The WS1D **shall** handle the special UPB Link Packet commands of “Activate” and “Deactivate”. When the WS1D accepts the “Activate” command it **shall** set its dimmer’s output using the Light Level and Fade Rate parameters of the “linked” Receive Component. When the WS1D accepts the “Deactivate” command it **shall** set its dimmer’s output to 0% using the Fade Rate parameter of the “linked” Receive Component.

8.1.3.Changing Preset Light Levels and Fade Rates

The Receive Components Light Level and Fade Rate parameters can be changed (configured) with the use of a UPB Setup Tool. In addition, the WS1D **shall** handle the special UPB Link Packet command of “Store Preset”. When the WS1D accepts the “Store Preset” command it **shall** store its current Light Level (%) into the “linked” Receive Component (Preset).

8.2. Receiving The Core Command Message Set

The WS1D **shall** be capable of handling received UPB Messages from the UPB Core Command Message Set as described in the [UPB System Description](#) document.

8.3. Receiving The Device Control Command Set

Besides handling the UPB Core Commands, the WS1D **shall** also handle the following set of UPB Commands from the UPB Device Control Command Set (see Table 11).

MDID (Hex)	Command Name	Command Description
0x20	Activate	Commands the WS1D to “activate” its linked Receive Component’s (Preset) Light Level and Fade Rate.
0x21	Deactivate	Commands the WS1D to “deactivate” its linked Receive Component’s (Preset) Light Level and Fade Rate.

MDID (Hex)	Command Name	Command Description
0x22	Goto	Commands the WS1D to set its dimmer output to the specified Light Level at the specified Fade Rate.
0x23	Fade Start	Commands the WS1D to set its dimmer output to the specified Light Level at the specified Fade Rate as long as the Dimming Option bit is set to 1 (i.e. Dimming-Capable).
0x24	Fade Stop	Commands the WS1D to stop fading and stay at the current Light Level.
0x25	Blink	Commands the WS1D to blink its dimmer output from 0% to 100% at the specified Blink Rate.
0x30	Report State	Commands the WS1D to send back a Device State Report containing the current dimmer Light Level (%).
0x31	Store Preset	Commands the WS1D to store its current dimmer Light Level (%) value as its linked Receive Component's (Preset) new Light Level.

Table 11: WS1D UPB Device Control Commands

8.4. The “Activate” Command

When the WS1D receives and accepts an “Activate” Command message (MDID = 0x20) in a UPB Link Packet it **shall** set its Dimmer’s light level to the Light Level value of the linked Receive Component (Preset) using the Fade Rate of the linked Receive Component (Preset).

8.5. The “Deactivate” Command

When the WS1D receives and accepts a “Deactivate Link” Command message (MDID = 0x21) in a UPB Link Packet it **shall** set its Dimmer’s light level to 0% (OFF) using the Fade Rate of the linked Receive Component (Preset).

8.6. The “Goto” Command

When the WS1D receives and accepts a “Goto” Command message (MDID = 0x22) in a UPB Link Packet or a UPB Direct Packet it **shall** start its Light Dimmer fading its light level towards the specified Light Level using the specified Fade Rate. If no Fade Rate is specified in the command then the WS1D **shall** use its Default Fade Rate instead.

8.7. The “Fade Start” Command

When the WS1D receives and accepts a “Fade Start” Command message (MDID = 0x23) in a UPB Link Packet or a UPB Direct Packet it **shall** start its Light Dimmer fading its light level towards the specified Light Level using the specified Fade Rate. If no Fade Rate is specified in the command then the WS1D **shall** use its Default Fade Rate instead. This command **shall** be ignored if the Dimming Capable Flag in the Dimmer Options Register is set to 0 (not dimming capable).

8.8. The “Fade Stop” Command

When the WS1D receives and accepts a “Fade Stop” Command message (MDID = 0x24) in a UPB Link Packet or a UPB Direct Packet it **shall** stop its Light Dimmer from fading its light level any farther.

8.9. The “Blink” Command

When the WS1D receives and accepts a “Blink” Command message (MDID = 0x25) in a UPB Link Packet or a UPB Direct Packet it **shall** alternate its light level between 100% and 0% at the specified Blink Rate. The WS1D **shall** calculate the time between blinking as:

$$\text{Time between blinking} = 16.667\text{mS} * \text{Blink Rate value}$$

If no Blink Rate value is specified in the command then the WS1D **shall** use a default Blink Rate value of 30 (0.5 seconds) instead.

8.10. The “Store Preset” Command

When the WS1D receives and accepts a “Store Preset” Command message (MDID = 0x31) in a UPB Link Packet it **shall** store its current Light Level value into the linked Preset Component.

8.11. The “Report Status” Command

When the WS1D receives and accepts a “Report Status” Command message (MDID = 0x30) in a UPB Direct Packet it **shall** build and transmit a Device State Report message.

The “Device State” Report has a Message Data ID of **0x86** and has the following syntax:

MDID	Arg1
0x86	LL

Where LL is the current Light Level % (0x00 – 0x64) of the WS1D dimmer.

9. Rocker Switch Triggered Transmissions

Besides controlling the WS1D’s light level and modes of operation, the two Rocker Switches can be configured to trigger transmissions of UPB Messages whenever any of their defined Rocker Switch Events occur. The WS1D factory defaults are set up to not perform any UPB transmissions upon Rocker Switch Events but this configuration can be changed with the use of a UPB Setup Tool. This section will describe the various Setup Registers involved with configuring Rocker Switch transmissions.

9.1. Transmit Components

The WS1D uses the concept of Transmit Components (as described in the UPB System Description document) for configuring its two Rocker Switches for Rocker Switch Triggered Transmissions. The WS1D has two Transmit Components: one for the Top Rocker Switch and one for the Bottom Rocker Switch (Figure 6).

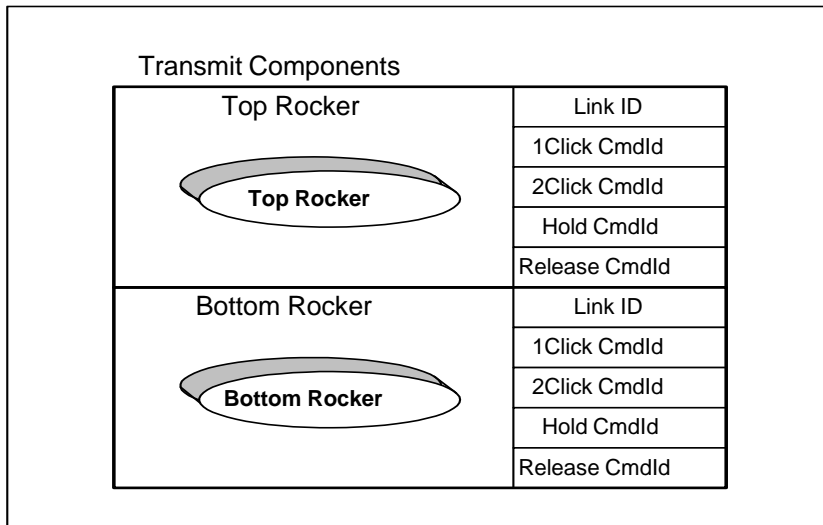

Figure 6: WS1D Transmit Components

The WS1D **shall** implement its two Transmit Components in its non-volatile Configuration Registers as a 10-byte Transmit Component Table as described in Table 12. One Transmit Component is associated with the Top Rocker Switch and the other Transmit Component is associated with the Bottom Rocker Switch. Each Transmit Component **shall** have, as its 1st byte, an associated Link ID byte that is used when transmitting UPB Link Packets. Each Transmit Component **shall** also have an associated byte for holding a Command ID for each of four possible Rocker Switch Events: Single-Tap, Double-Tap, Hold, and Release.

Setup Register Field Name	Register Numbers	Factory Default Values				
		Link ID	1-Tap	2-Tap	Hold	Release
Top Rocker Trigger	0x70 – 0x74	255 (0xFF)	255 (0xFF)	255 (0xFF)	255 (0xFF)	255 (0xFF)
Bottom Rocker Trigger	0x75 – 0x79	255 (0xFF)	255 (0xFF)	255 (0xFF)	255 (0xFF)	255 (0xFF)

Table 12: Transmit Component Table

9.1.1. The Transmit Link ID

Each Transmit Component Record **shall** start with a 1-byte Link ID. Each Transmit Component can either be assigned a Valid Link ID (from 1 to 254) or an Invalid Link ID (0 and 255). If it is assigned an invalid Link ID (the factory default) then no Rocker Switch Transmissions **shall** take place. If it is assigned a Valid Link ID, however, then it **shall** use that Link ID in the Destination ID field of any configured Rocker Switch Transmissions.

9.1.2. The Transmit Command ID

Each Transmit Component record has four additional bytes that can be assigned a 4-bit Command ID (0 – 15). There is a Command ID byte for each of the four defined Rocker Switch Events: Single-Tap, Double-Tap, Hold, and Release. The lower 4 bits of each byte represent the configured Command ID to be used for the associated Rocker Switch Event. The upper 4 bits are ignored. For example, if a Hold event occurs then the lower 4-bits of the 3rd Command ID byte will be used to determine what command to transmit.

9.2. Using Command IDs

The 4-bit Command ID **shall** be used by the WS1D to determine what UPB Message to build and transmit. If the Command ID value is 15 then no UPB Message **shall** be built or transmitted. If the Command ID value is 14 then the WS1D shall build and transmit a Device State Report message as described in section 9.3.1. If the Command ID value is between 0 and 13 then the WS1D **shall** use the Command ID as an index into the UPB Transmit Command Table to look-up a three-byte command message to be built and transmitted.

9.3. The UPB Transmit Command Table

The WS1D **shall** implement a UPB Transmit Command Table in its non-volatile Setup Registers that allows for the customization of up to fourteen 3-byte UPB Messages. Table 13 shows the UPB Transmit Command Table for the WS1D along with its factory default values. Each three-byte record corresponds to a Command ID value (0 – 13). The WS1D **shall** use the UPB Transmit Command Table to look-up the three-byte UPB Message to build and transmit onto the UPB bus for the configured Command ID. The UPB Transmit Command Table can be

changed with the use of a UPB Setup Tool so that other custom commands can be formed.

Setup Register Field Name	Reg. Num.	Cmd ID	Factory Default	Command Name
Tx Command #0	0x90 – 0x92	0	22 00 FF	Goto Off
Tx Command #1	0x93 – 0x95	1	22 64 FF	Goto On
Tx Command #2	0x96 – 0x98	2	23 00 FF	Fade Down
Tx Command #3	0x99 – 0x9B	3	23 64 FF	Fade Up
Tx Command #4	0x9C – 0x9E	4	24 FF FF	Fade Stop
Tx Command #5	0x9F – 0xA1	5	21 FF FF	Deactivate
Tx Command #6	0xA2 – 0xA4	6	20 FF FF	Activate
Tx Command #7	0xA5 – 0xA7	7	22 00 00	Snap Off
Tx Command #8	0xA8 – 0xAA	8	22 64 00	Snap On
Tx Command #9	0xAB – 0xAD	9	22 00 01	Quick Off
Tx Command #10	0xAE – 0xB0	10	22 64 01	Quick On
Tx Command #11	0xB1 – 0xB3	11	22 00 08	Slow Off
Tx Command #12	0xB4 – 0xB6	12	22 64 08	Slow On
Tx Command #13	0xB7 – 0xB9	13	25 1E FF	Blink

Table 13: The Transmit Command Table

9.3.1. Send State Report

The WS1D uses the Command ID value of 14 in a special way. If the Command ID value for a valid Rocker Switch Event is 14 then the WS1D **shall** build and transmit a Device State Report. The Device State Report shall include the current Setpoint value of the WS1D’s dimmer. The syntax of the Device State Report is as follows:

MDID	Arg1
0x86	SP

Where SP is the current Setpoint % (000 – 100) of the WS1D dimmer.

9.4. The UPB Transmit Control Register

The WS1D **shall** have an 8-bit UPB Transmit Control Register implemented in its non-volatile Setup Registers that allows for the customization of its Rocker Switch Triggered Transmissions. Figure 7 shows the UPB Transmit Control Register and explains the meanings of its various bits and fields. The UPB

Transmit Control Register can be changed with the use of a UPB Setup Tool so that the Rocker Switch Triggered Transmissions behavior of the WS1D can be customized.

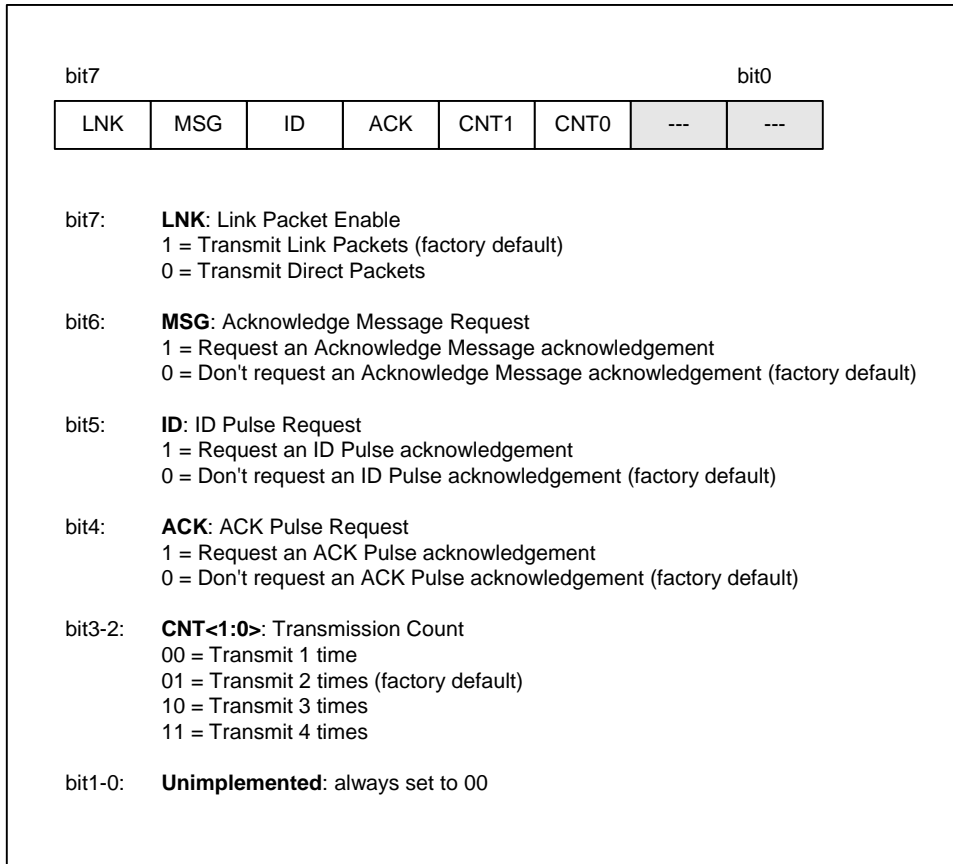

Figure 7: The UPB Transmit Control Register

9.4.1. Link Packet Enable

Bit #7 of the UPB Transmit Control Register is used to configure whether Rocker Switch Triggered Transmissions are sent in Link Packets or Direct Packets. If this bit is set to '0' the WS1D **shall** build and transmit all Rocker Switch Triggered Transmissions with the LNK-bit cleared in its Control Word (Direct Packet). If this bit is set to '1' the WS1D **shall** build and transmit all Rocker Switch Triggered Transmissions with the LNK-bit set in its Control Word (Link Packet).

9.4.2. Acknowledge Message Request

Bit #6 of the UPB Transmit Control Register is used to configure whether an Acknowledge Message is requested from the receiver of any Rocker Switch Triggered Transmissions. If this bit is set to '1' the WS1D **shall** build and transmit all Rocker Switch Triggered Transmissions with the MSG-bit set in its Control Word.

9.4.3.ID Pulse Request

Bit #5 of the UPB Transmit Control Register is used to configure whether an ID Pulse is requested from the receiver of any Rocker Switch Triggered Transmissions. If this bit is set to '1' the WS1D **shall** build and transmit all Rocker Switch Triggered Transmissions with the ID-bit set in its Control Word.

9.4.4.ACK Pulse Request

Bit #4 of the UPB Transmit Control Register is used to configure whether an ACK Pulse is requested from the receiver of any Rocker Switch Triggered Transmissions. If this bit is set to '1' the WS1D **shall** build and transmit all Rocker Switch Triggered Transmissions with the ACK-bit set in its Control Word.

9.4.5.Transmission Count

Bit #3 and #2 of the UPB Transmit Control Register are used to configure how many times to transmit a message in a row for each Rocker Switch Triggered Transmission event. If this field is set to 00 the WS1D **shall** transmit any Rocker Switch Triggered Transmission one time only. If this field is set to 01 or 10 or 11 the WS1D **shall** transmit any Rocker Switch Triggered Transmission two times or three times or four times respectively.

10. Automatic State Report Transmissions

Besides controlling the WS1D’s light level and modes of operation, the two Rocker Switches can be configured to trigger transmissions of State Reports whenever they are single-tapped, double-tapped, or released. These Automatic State Reports are perfect for letting home automation controllers know when someone has altered a light level via a rocker switch action.

10.1. Enabling Automatic State Reports

Automatic State Report Transmissions are enabled by setting bit#4 of the Dimmer Options Register (Figure 4). If Automatic State Report Transmissions are enabled the WS1D **shall** build and transmit a State Report message whenever a Rocker Switch is single-tapped, double-tapped, or released.

10.2. Transmitting Automatic State Reports

The Automatic State Report Transmissions **shall** always be sent in a Direct Packet. The Automatic State Report Transmissions **shall** always be directed to the same Network ID as the WS1D is assigned to. The Automatic State Report Transmissions **shall** always be directed to the Broadcast Destination ID (0x00).

The Data field of the Automatic State Report Transmissions **shall** contain a “Device State” Report. The “Device State” Report has a Message Data ID of **0x86** and has the following syntax:

MDID	Arg1
0x86	LL

Where LL is the current Light Level % (0x00 – 0x64) of the WS1D dimmer.

11. Factory Default Operation

This section describes the operation of the WS1D with its factory default settings enabled. These settings will be enabled “right out of the box” or whenever Factory Default Mode is enabled as described in section 5.5.3.

11.1. Power-Up Operation

Upon power-up the WS1D will enter Normal Mode and will display its current firmware version by blinking its LED four times as described in section 7.6. It will then read the saved Reset Light Level from non-volatile memory and set its dimmer’s light level to the Reset Light Level at the Default Fade Rate (3.3 seconds). The WS1D will set its LED color to orange and await further events such as Local Rocker Switch Events, Slave Rocker Switch Events, or UPB Communication Packet Receptions.

11.2. Dimmer Operation

The WS1D factory default is for dimming-capable whereby its dimmer can produce 200 different light levels as well as off that it fades between using a pseudo-logarithmic dimming curve. The WS1D factory default value for its Default Fade Rate is 3. With this value, the WS1D will span the lighting range from 0% to 100% in approximately 3.3 seconds. The Default Fade Rate is used whenever the specified Fade Rate is an illegal value (above 15).

11.3. Local Rocker Switch Events

The Local Rocker Switch can be used to change the WS1D dimmer’s light level as described in Table 14.

Rocker Event	Dimmer Action (Top Rocker)	Dimmer Action (Bottom Rocker)
Single-Tap	Fade to 100% at the Default Fade Rate.	Fade to 0% at the Default Fade Rate.
Double-Tap	Snap to 100% at Fade Rate #0.	Snap to 0% at Fade Rate #0.
Hold	Start fading to 100% at the Default Fade Rate.	Start fading to 0% at the Default Fade Rate.
Release	Stop fading the Light Level.	Stop fading the Light Level.

Table 14: Local Rocker Switch Dimmer Actions

The Local Rocker Switch can also be used to put the WS1D into Setup Mode and Factory Default Mode as described in section 5.5

11.4. Slave Rocker Switch Events

The optional Slave Rocker Switch can be used to change the WS1D dimmer's light level as described in Table 15.

Rocker Event	Dimmer Action (Top Rocker)	Dimmer Action (Bottom Rocker)
Single-Tap	Fade to 100% at the Default Fade Rate.	Fade to 0% at the Default Fade Rate.
Double-Tap	Snap to 100% at Fade Rate #0.	Snap to 0% at Fade Rate #0.
Hold	Start fading to 100% at the Default Fade Rate.	Start fading to 0% at the Default Fade Rate.
Release	Stop fading the Light Level.	Stop fading the Light Level.

Table 15: Slave Rocker Switch Dimmer Actions

The Slave Rocker Switch can also be used to put the WS1D into Setup Mode and Factory Default Mode as described in section 5.5

11.5. UPB Communication Packet Receptions

The WS1D has a factory default Network ID of 255 and a factory default Unit ID of 001. It is capable of handling the UPB Core Command Message Set (as described in the [UPB System Description](#) document) for Direct Packets sent to this NID/UID. Besides handling the UPB Core Commands, the WS1D also handles the set of UPB Commands described in Table 11.

11.6. UPB Receive Components

The WS1D has 16 Receive Components (called Presets) that are configured for receiving Link Packets addressed to its NID. The factory default Link IDs that the WS1D will accept are Link IDs #1 through #16 as shown in Table 16.

Receive Component	Link ID	Light Level	Fade Rate
Preset #1	001	100%	Default Fade Rate
Preset #2	002	0%	Default Fade Rate
Preset #3	003	80%	Default Fade Rate
Preset #4	004	60%	Default Fade Rate
Preset #5	005	40%	Default Fade Rate
Preset #6	006	20%	Default Fade Rate
Preset #7	007	100%	Default Fade Rate
Preset #8	008	0%	Default Fade Rate
Preset #9	009	80%	Default Fade Rate

Receive Component	Link ID	Light Level	Fade Rate
Preset #10	010	60%	Default Fade Rate
Preset #11	011	40%	Default Fade Rate
Preset #12	012	20%	Default Fade Rate
Preset #13	013	100%	Default Fade Rate
Preset #14	014	100%	Default Fade Rate
Preset #15	015	100%	Default Fade Rate
Preset #16	016	100%	Default Fade Rate

Table 16: Factory Default Presets

11.7. Activate Link Command Operation

The WS1D has 16 Receive Components (called Presets) that are setup for receiving Link Packets with Link IDs #1 through #16. Each Preset has a Light Level and Fade Rate parameter associated with it that will be “activated” by the Link Activate command. Whenever the WS1D receives a Link Activate command addressed to its NID and one of these Link IDs it will set its dimmer output to the associated Light Level at the associated Fade Rate (see Table 16).

11.8. Deactivate Link Command Operation

The WS1D has 16 Receive Components (called Presets) that are setup for receiving Link Packets with Link IDs #1 through #16. Each Preset has a Light Level and Fade Rate parameter associated with it that will be “deactivated” by the Link Deactivate command. Whenever the WS1D receives a Link Deactivate command addressed to its NID and one of these Link IDs it will set its dimmer output to 0% (off) at the associated Fade Rate (see Table 16).

11.9. Changing Preset Light Levels

The WS1D has 16 Receive Components (called Presets) that are setup for receiving Link Packets with Link IDs #1 through #16. Each Preset has a Light Level and Fade Rate parameter associated with it. Whenever the WS1D receives a Store State command addressed to its NID and one of these Link IDs it will store its current dimmer Light Level into the associated Light Level parameter of the Preset.

11.10. UPB Communication Packet Transmissions

The WS1D will transmit UPB Communication Packets onto the powerline in response to various commands from the UPB Core Command Message Set (as described in the [UPB System Description](#) document). The WS1D factory default setting is for no Rocker Switch Transmissions.